

Design data

Vessel category	Normal pressure	
	Vessel	Jacket
Description of parameter		
Working pressure bar	ATPM	-----
Design pressure bar	ATPM	-----
Level tesing pressure bar	ATPM	-----
Medium		-----
Material	SUS 304	-----
Working temperature °C	-10 to +40°C	
Design temperature °C	-10 to +40°C	
Gross volume GAL	36	
Net volume GAL	30	
Heat exchanger area m²	-----	
Insulation material	-----	
Insulation thickness mm	-----	
Dry Weight KGS		

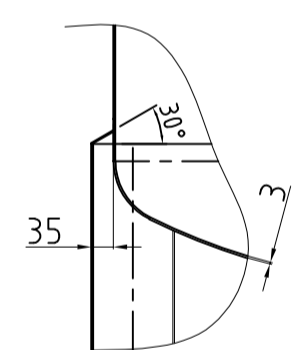
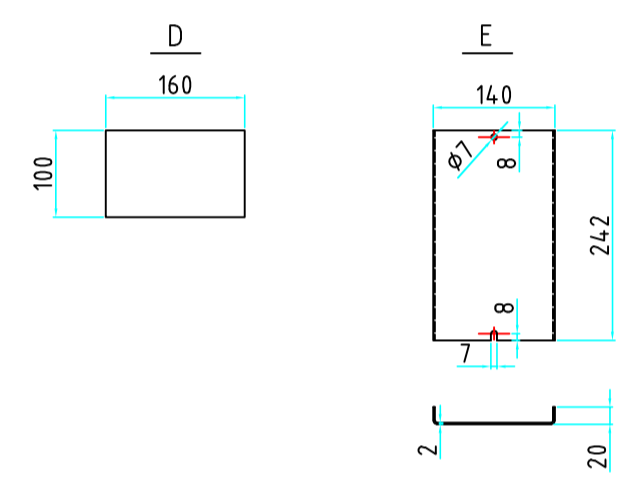

CONNECTIONS

MARK	DN	DESCRIPTION	CONNECT SIZE	REMARKS
A	1.5"TC	InLet	φ38.1x1.5	ISO
B	1.5"TC	InLet	φ38.1x1.5	ISO
C	1.5"TC	OutLet	φ38.1x1.5	ISO
D	4"×6.3"	Nameplate	100×160	
E	2.5"×9.6"	VFD Support	140×242	

03/14/2020
30GAL MIXING TANK